



CO₂ laser consumables – Cincinnati®



Hypertherm®

Highest quality products

- OEM quality
- OEM-approved optics
- 100% satisfaction guarantee

Technical service

OEM-trained technicians on staff with over 25 years of experience.

Free application support for all laser OEMs.

We stand behind our products with industry-leading technical expertise.

Chemical code key

Lens

PFL	Pre-focus
MEN	Meniscus
PLX	Plano-convex
MTD	Mounted
Not MTD	Not mounted
LA	Low absorption
PO	Plano

Mirrors

CU	Copper
GAAS	Gallium arsenide
SI	Silicon
GE	Germanium
ZNSE	Zinc-selenide
PS	Phase shift
MMR	Maximum metal reflector
ATFR	Absorbing thin film reflector
TRZ	Total reflector – zero phase shift
ZPS	Zero phase shift
OC	Output coupler
RM	Rear mirror
COL-I	Collimator input
COL-O	Collimator output
AO	Adaptive optic
MO	Molybdenum
UC	Uncoated
MCX	Convex
MCC	Concave

Measurements

DIA	Diameter
FL	Focal length
ET	Edge thickness

Nozzles

CP	Chrome plated
HD/HP	High density/high pressure

Product is available for the following major OEM brands

Amada®

Behrens®

Bystronic®

Cincinnati®

Finn-Power®

GHT-SHT®

Haas®

Haco®

Hankwang®

Laserdyne®

Laser Lab®

LVD®

Mazak®

Mitsubishi®

Murata Wiedemann® – Fanuc®

Niigata®

NTC® – Beyeler®

Precitec®

Prima Industrie®

Raskin®

Rouchaud®

Salvagnini®

Strippit®

Tanaka®

Thyssen®

Trumpf®

Valfiv®

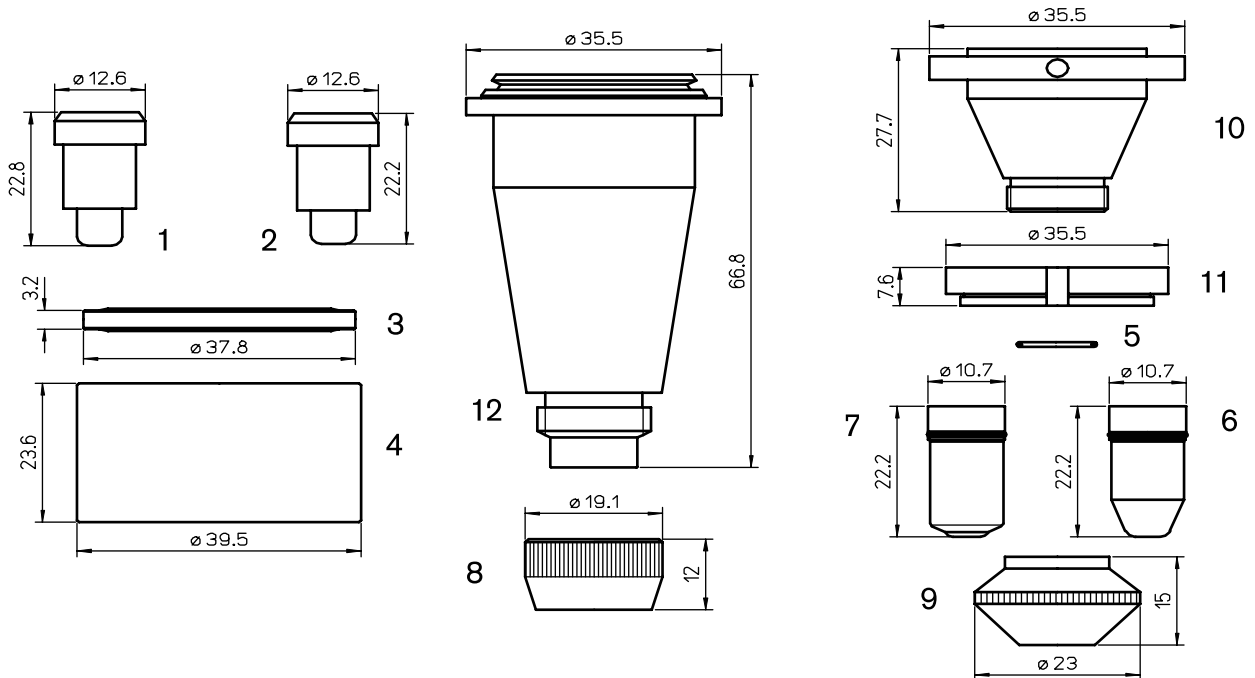

Consumables

	Centricut part number	Reference number	Alternate reference	Description	Pkg qty
1	CN305-8090	908090	L220	Elongated nozzle – 1.5 mm (0.060")	1
	CN305-7469	907469	L221	Nozzle – 1.0 mm (0.040")	1
2	CN305-7470	907470	L222	Nozzle – 1.5 mm (0.060")	1
	CN305-0006	920006	L223	Nozzle – 2.0 mm (0.080")	1
3	CN305-0000		AL92	Gasket – Teflon [®] w/spring	1
4	CN305-7677	907677	AL71/S	Nozzle holder – contact	1
	CN305-7472	907472	AL71	Nozzle holder – contact w/gasket	1
5	CN306-9680	909680	AL95	O-ring	1
	CN306-9660-1	924635	L712	Nozzle – 1.0 mm (0.040")	1
	CN306-0012		L961	Nozzle – 1.2 mm (0.045")	1
	CN306-0013		L962	Nozzle – 1.3 mm (0.050")	1
	CN306-0014		L963	Nozzle – 1.4 mm (0.055")	1
	CN306-9660	909660	L224	Nozzle – 1.5 mm (0.060")	1
	CN306-0315	910315	L225	Nozzle – 2.0 mm (0.080")	1
6	CN306-3789	924638	L713	Nozzle – 2.5 mm (0.100")	1
	CN306-4634	924634	L714	Nozzle – 3.0 mm (0.120")	1
	CN306-5127	925127	L938	Nozzle – 3.2 mm (0.125")	1
	CN306-2815	912815	L724	Nozzle – 4.0 mm (0.160")	1
	CN306-3013	923013	L433	Nozzle – 1.0 shower (0.040")	1
	CN306-3014	923014	L434	Nozzle – 1.5 shower (0.060")	1
	CN306-0020		L435	Nozzle – 2.0 shower (0.080")	1
7	CN306-4636	924636	L869	Nozzle – 1.5 mm (0.060")	1
	CN306-4637	924637	L870	Nozzle – 2.0 mm (0.080")	1
	CN306-9910 (not shown)	913025	L1018	Nozzle – 1.0 mm (0.040") double	1
	CN306-9915 (not shown)		L1019	Nozzle – 1.5 mm (0.060") double	1
	CN306-9920 (not shown)	913027	L1020	Nozzle – 2.0 mm (0.080") double	1
	CN306-9925 (not shown)		L1021	Nozzle – 2.5 mm (0.100") double	1
8	CN306-9659	909659	AL48	Tip lock nut	1
9	CN306-3021	963021	AL135	Tip retainer nut	1
10	CN306-0150	923258	AL137	Nozzle body	1
11	CN306-0001	923259	AL139	Insulator ring	1
12	CN306-9658	909658	AL183	Tip retainer extension	1
	CN306-9664	909664, 56161		O-ring	1

New items shown in bold

Centricut is a registered trademark of Hypertherm, Inc. and may be registered in the United States and/or other countries. All other trademarks are the properties of their respective owners. Centricut is in no way affiliated with Cincinnati.

Consumables

Centricut part number	Reference number	Alternate reference	Description	Pkg qty
CN306-0654A	909654, 922686		Sensor cable – armored 4.5	1
CN306-0951A	842951		Sensor cable – armored 5.5	1
CN306-9654	909654, 922686		Sensor cable 4.5	1
CN306-2951	842951, PLTTW0015		Sensor cable 5.5	1

Optics

Centricut part number	Reference number	Type	Diameter	Focal length	Edge thickness
Lenses					
CN307-7557		PLX	1.5"	5.0"	.160"
CN307-8085	908085	PLX	1.5"	5.0"WD	.280"
CN307-9484	909484	PLX	1.5"	7.5"WD	.280"
CN307-2722	922722	PLX	2.0"	4M	.236"
CN307-0676	922377	PLX	2.0"	5.0"WD	.380"
CN307-1603	922376	PLX	2.0"	7.5"WD	.380"
CN307-2377	922377	PLX	2.0"	5.0"	.380"
CN307-2376	922376	PLX	2.0"	7.5"	.380"
CN307-4498		PLX	2.0"	10.0"WD	.380"
Ultra low absorption lenses					
CN307-8085MP5	908085	PLX	1.5"	5.0"WD	.280"
CN307-9484MP5	909484	PLX	1.5"	7.5"WD	.280"
CN307-2377MP5	922377	PLX	2.0"	5.0"	.380"
CN307-0211MP5		PLX	2.0"	5.0"WD	.380"
CN307-2376MP5	922376	PLX	2.0"	7.5"	.380"

Centricut part number	Reference number	Type	Diameter	Edge thickness	S1
Collimating optics					
CN307-0296	920296	OUTPUT	1.97"	.375"	2.44MCC
CN307-0295	920295	INPUT	1.97"	.375"	1.73MCX

Centricut part number	Reference number	Material	Diameter	Edge thickness	S1
Phase shift mirrors					
CN307-8237	498237	SI	1.5"	.160"	
CN307-5587	335587	SI	2.0"	.200"	
CN307-5214		CU	1.969"	.375"	
CN307-9975	909975	CU	2.25"	.390"	
CN307-2768	922768	CU	2.25"	1.25"	WC
CN307-2515	922515	CU	2.5"	.390"	

Centricut part number	Reference number	Material	Diameter	Edge thickness	Reflectivity
Absorbing thin film reflectors (ATFR)					
CN307-3414	923414	CU	2.0"	.375"	99.50%

New items shown in bold

Optics

Centricut part number	Reference number	Type	Material	Diameter	Edge thickness	S1
Zero phase shift mirrors and total reflectors						
CN307-7753		TRZ	CU	1.96"	1.0"	
CN307-3849	233849	TRZ	CU	1.96"	.375"	
CN307-1793		TRZ	CU	1.5"	.236"	
CN307-2645	922645	MMR	SI	2.0"	.200"	PLANO
CN307-9772	909772	TRZ	CU	2.0"	2.126"	PLANO WC
CN307-2992		TRZ	SI	2.0"	.200"	45D
CN307-7971	907971	TRZ	SI	2.0"	.200"	
CN307-9976	909976	ZPS	CU	2.25"	.390"	
CN307-2769	922769	ZPS	CU	2.25"	1.25"	WC
CN307-3010	923010	TRZ	CU	3.0"	.500"	
CN307-0341	910341	ZPS	CU	3.0"	.500"	

Centricut part number	Reference number	Material	Diameter	Edge thickness	S1/Reflectivity	S2
Output couplers						
CN307-7969	907969	ZNSE	1.0"	.236"	30MCC-65%	30MCX
CN307-4510	924510	ZNSE	1.5"	.315"	15MCC-40%	
CN307-3604		ZNSE	1.5"	.315"	40MCC-50%	
CN307-2668	922668	ZNSE	1.5"	.315"	51.6MCC-50%	25MCX

Centricut part number	Reference number	Material	Diameter	Edge thickness	S1/Reflectivity	S2
Rear mirrors						
CN307-7970	907970	GE	1.0"	0.236"	15MCC-99.5%	PO/AR
CN307-4511	924511	GE	1.5"	.315"	15MCC-99.5%	PO/AR
CN307-3603		GE	1.5"	.315"	40MCC-99.5%	PO
CN307-2644	922644	GE	1.5"	.315"	51.6MCC-99.5%	PO/AR

Optics care

Centricut part number	Reference number	Description	Pkg qty
TR300-6452	N/A	CO ₂ Lens paper (50 sheets)	1
TR300-SC20		Cotton swab – 20 piece	1
TR300-1115		Lens cleaning pre-cut cotton –100 piece	1
TR300-1010	AL1010	Dropper, lens cleaning fluid	1
TR300-255	AL255	Loupe, magnifying	1
TR300-271	AL271	Base, lens maintenance	1
TR300-7388	787388	Mirror polish (250 ml)	1

New items shown in bold



Broadest product line in the industry!



Hypertherm, Inc.
Hanover, NH 03755 USA
603-643-3441 Tel

Hypertherm Europe B.V.
4704 SE Roosendaal, Nederland
31 165 596907 Tel

**Hypertherm (Shanghai)
Trading Co., Ltd.**
PR China 200052
86-21 5258 3330 /1 Tel

Hypertherm (S) Pte Ltd.
Singapore 349567
65 6 841 2489 Tel

**Hypertherm (India) Thermal
Cutting Pvt. Ltd.**
Chennai, Tamil Nadu
91 0 44 2834 5361 Tel

Hypertherm Brasil Ltda.
Guarulhos, SP - Brasil
55 11 2409 2636 Tel

Hypertherm México, S.A. de C.V.
México, D.F.
52 55 5681 8109 Tel

www.hypertherm.com



Hypertherm[®]

Cut with confidence[®]